

NETAFLEX™ 3G

INSTALLATION MANUAL

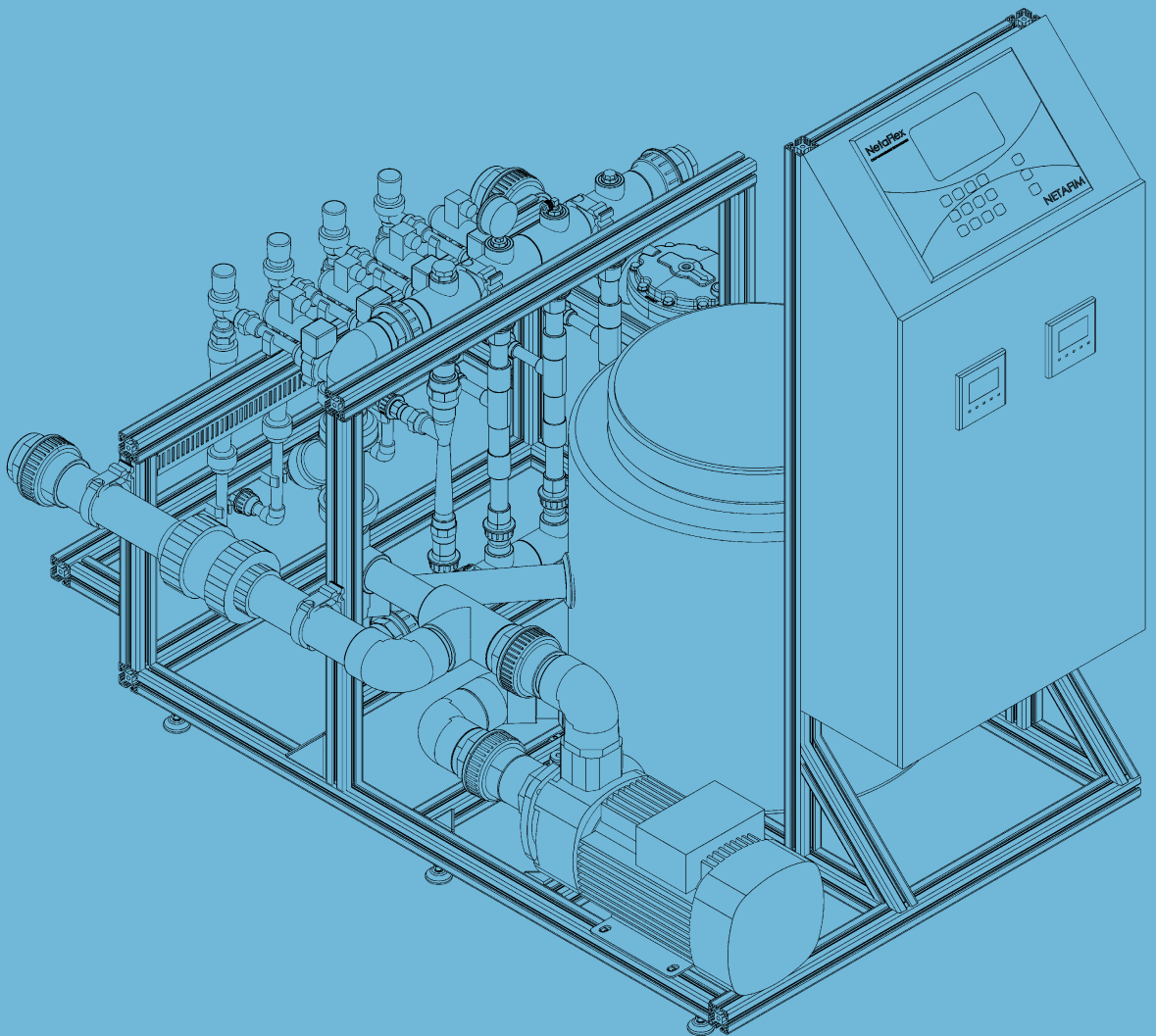

© COPYRIGHT 2013, NETAFIM

NO PARTS OF THIS PUBLICATION MAY BE REPRODUCED, STORED IN AN AUTOMATED DATA FILE OR MADE PUBLIC IN ANY FORM OR BY ANY MEANS, WHETHER ELECTRONIC, MECHANICAL, BY PHOTOCOPYING, RECORDING OR IN ANY OTHER MANNER WITHOUT PRIOR WRITTEN PERMISSION OF THE PUBLISHER.

ALTHOUGH NETAFIM TAKES THE GREATEST POSSIBLE CARE IN DESIGNING AND PRODUCING BOTH ITS PRODUCTS AND THE ASSOCIATED DOCUMENTATION, THEY MAY STILL INCLUDE FAULTS.

NETAFIM WILL NOT ACCEPT RESPONSIBILITY FOR DAMAGE RESULTING FROM THE USE OF NETAFIM'S PRODUCTS OR THE USE OF THIS MANUAL.

NETAFIM RESERVES THE RIGHT TO MAKE CHANGES AND IMPROVEMENTS TO ITS PRODUCTS AND/OR THE ASSOCIATED DOCUMENTATION WITHOUT PRIOR NOTICE.



FOREIGN LANGUAGES

In the event that you are reading this manual in a language other than the English language, you acknowledge and agree that the English language version shall prevail in case of inconsistency or contradiction in interpretation or translation.

CONTENTS

Use of symbols	6
Introduction	
General instructions	7
Safety instructions	7
When using acid/chemicals	8
Description	
Introduction	9
Highlights	9
Advantages	9
Specifications	10
Basic functions	10
Operating principle	10
Service	10
Maintenance	10
Add-ons	11
Schematic diagram	11
Typical installation overview	12
Dimensions	13
Weights	13
On-site preparations	
Hydraulic infrastructure preparation	14
Electrical preparation	17
Installation	
Unpacking and placement	18
Hydraulic installation	18
Electrical installation	20
System operation	
Preparations for running the NetaFlex™ 3G	21
Running the NetaFlex™ 3G	22
Calibration	
Calculation of dosing channels opening percentage	24
Simulation with a 10 liter (2 US gal) bucket of water	24
Calibration of the NetaFlex™ 3G while irrigating	26
Commissioning	28
Warranty	29
Appendices	
Appendix 1 - NetaFlex™ 3G parts list	30
Appendix 2 - System pump electrical data	35

TABLES, FIGURES AND DIAGRAMS

Tables

1	Dosing channels for acid	8
2	NetaFlex™ 3G dimensions	13
3	NetaFlex™ 3G weights	13
4	Hydraulic infrastructure required proportions	14
5	Location of connectors	15
6	Components of the water distribution system	16
7	Recommended flow meter pulse rate	16
8	Components of the fertilizer/acid tanks and lines	16
9	Mains wire size for three phasic system	17
10	NetaFlex™ inlet/outlet types of connectors	18
11	Fertilizer/acid lines types of connections	19
12	Parts list - Main parts	32
13	Parts list - Dosing channel parts	34
14	Parts list - Venturis	34
15	Parts list - System pumps for 50 Hz installations	35
16	Parts list - System pumps for 60 Hz installations	35

Figures

1	Typical installation overview	12
2	External dimensions	13
3	Hydraulic infrastructure - required proportions	14
4	Location of connectors	15
5	The ShockWatch label	18
6	Fertilizer/acid lines connection	19
7	Rotation of the hose connectors	19
8	The dual dosing channel	20
9	The dosing valve selector	21
10	Adjustment of the Rotameter cursors	22
11	Simulation test with a 10 liter (2 US gal) bucket of water	25
12	EC and pH range	25
13	Parts - 100 L - Horizontal pump	30
14	Parts - 200 L - Vertical pump	31
15	Parts - Dosing channel	33
16	Parts - Venturis	34

Diagrams

1	Schematic diagram	11
2	Infrastructure schematic diagram	12
3	The dual dosing channel	20

USE OF SYMBOLS

The symbols used in this manual refer to the following:



WARNING

The following text contains instructions aimed at preventing bodily injury or direct damage to the crops, the NetaFlex™ 3G and/or the infrastructure.



CAUTION

The following text contains instructions aimed at preventing unwanted system operation, installation or conditions that, if not followed, might void the warranty.



ATTENTION

The following text contains instructions aimed at enhancing the efficiency of usage of the instructions in the manual.



NOTE

The following text contains instructions aimed at emphasizing certain aspect of the operation of the system or installation.



ACID HAZARD

The following text contains instructions aimed at preventing bodily injury or direct damage to the crops, the product and/or the infrastructure in the presence of acid.



ELECTRICAL HAZARD

The following text contains instructions aimed at preventing bodily injury or direct damage to the NetaFlex™ 3G and/or the infrastructure in the presence of electricity.



SAFETY FOOTWEAR

The following text contains instructions aimed at preventing foot injury.



PROTECTIVE EQUIPMENT

The following text contains instructions aimed at preventing damage to health or bodily injury in the presence of fertilizers, acid or other chemicals.



EXAMPLE

The following text provides an example to clarify the operation of the settings, method of operation or installation.

The values used in the examples are hypothetical. Do not apply these values to your own situation.



TIP

The following text provides clarification, tips or useful information.

INTRODUCTION



CAUTION

Read the Safety instructions chapter before beginning installation of the NetaFlex™ 3G dosing unit.

General instructions

- Installation must be performed by authorized technicians only.
- Refer to your supervisor if problems occur during installation procedure.
- Installation should be performed on a hard, leveled floor or on a flat, hard, leveled surface.
- Do not apply force or pressure on components during the installation procedure.
- Verify that field components work properly.
- Make sure fertilizers and acid are on site at time of installation.

Electricity

- Ensure that suitable electrical power supply is available in the vicinity of the installation for the NetaFlex™ 3G electrical connection (see - [Electrical Installation](#), p 20).
- Ensure an electrical socket available in the NetaFlex™ 3G vicinity, for installation and for service purposes.

Safety instructions

- All safety regulations must be applied.
- Ensure that the installation is carried out in a manner that prevents leaks from the NetaFlex™ 3G, the fertilizer/acid tanks and lines, the peripherals and the accessories, contaminating the environment, soil or ambient area.
- Electrical installation must be performed by an authorized electrician only.
- The electrical installation must comply with the local safety standards and regulations.
- Protection provided by the equipment can be impaired if the equipment is used in a manner other than that specified by the manufacturer.
- The NetaFlex™ 3G should be placed in an environment with pollution not exceeding degree 3.



WARNING

In agricultural environment - always wear protective footwear.



WARNING

Measures must be taken to prevent fertilizer infiltration of the water source, to avoid water pollution.



CAUTION

When opening or closing any manual valve, always do it gradually, to prevent damage to the system by water hammer.



NOTE

The maximum sound level produced by the equipment does not exceed 70dB.

INTRODUCTION

When using acid/chemicals



ACID HAZARD

When using acid - always observe the acid manufacturer's safety instructions.



WARNING

Always use protective equipment, gloves and goggles when handling fertilizers, acid and other chemicals!



ATTENTION

Table 1 - When dosing acid, respect the concentration of the acid used*:

Diaphragm and O-rings	For pH correction			For maintenance of drippers		
	Nitric (HNO ₃)	Phosphoric (H ₃ PO ₄)	Sulfuric (H ₂ SO ₄)	Hydrochloric (HCl)	Hydrogen peroxide (H ₂ O ₂)	Chlorine (as hypochlorite)
Viton	<40%	<85%	<90%	<33%	<50%	<10%

% is by weight at 21°C (70°F)

* The table indicates the resistance of the dosing channel components to acid, and is not a recommendation to use the acids mentioned.



WARNING

Exceeding the recommended acid concentrations will damage the dosing channels.



WARNING

Substances such as chemicals for pest/disease control might be corrosive and damage the NetaFlex™ 3G. When using any substance other than fertilizers or acids not exceeding the concentrations in table 1 above, always observe the manufacturer's instructions for corrosivity. In case of any doubt, consult your local Netafim™ representative.

DESCRIPTION

Introduction

The NetaFlex™ 3G is a reliable open-tank dosing system.

The NetaFlex™ 3G ensures very precise and homogeneous nutrient dosing for greenhouse crops.

The NetaFlex™ 3G is a modular CE-compliant dosing system that easily integrates with multiple Netafim™ and third-party control and monitoring systems.

The NetaFlex™ 3G always injects a uniform quantity of nutrients while performing perfect EC and pH control.

The NetaFlex™ 3G can accommodate a wide variety of dosing channels for fertilizer and concentrated/diluted acid. Up to 6 dosing channels of various types, from 50 l/h (13 GPH) each, up to 600 l/h (158 GPH) each, in many mixed configurations.

The NetaFlex™ 3G accommodates a wide variety of system pumps, peripherals and accessories to meet a vast range of applications and infrastructure constraints.

Highlights

- Wide range of soil/substrate applications
- Built around a standard platform
- Minimal investment requirement
- Efficient water, fertilizer and energy consumption
- Very large range of irrigation water capacities
- Quantitative or proportional Nutrigation capabilities
- Precise EC and pH control
- Almost completely maintenance-free Venturi operations - no moving parts
- Highly accurate dosing channels equipped with quick action dosing valves
- Fast and efficient Nutrigation recipe adjustments
- Easy integration into existing irrigation systems, Netafim's NMC, and third-party controllers
- Multilingual system
- Wide range of integrated accessories and peripherals
- High-quality components and PVC
- Aluminum, corrosion-resistant frame with adjustable legs
- Made by Netafim™

Advantages

- Easy to install and maintain system
- Highly profitable price/performance ratio
- Requires minimal investment with rapid ROI
- **Productive:** Employing precise EC and pH control assists in delivering a high quality product with outstanding yields (single or dual EC and pH control sets are available).
- **Uniform:** Delivers a consistent quantity or ratio of nutrients in a homogenous solution thanks to an open mixing tank design.
- **Flexible:** Works with a wide range of dosing channel flow rates up to 6 units of 50-600 l/h (13-158 GPH). Each dosing channel is fitted with a multipurpose dosing valve for the dosing of fertilizer or acid, at any dosing rate up to 600 l/h (158 GPH). Compatible with 50/60 Hz electricity frequency.
- **Scalable:** System flow rates from 3 m³/h (13 GPM) to 64 m³/h (282 GPM).
- **Focused:** Made for soil/soilless greenhouse applications.

DESCRIPTION

Specifications

Output flow rate and pressure

The NetaFlex™ 3G ensures a satisfactory mixture in a vast range of system performances. Flow rate from 3 m³/h (13 GPM) to 64 m³/h (282 GPM) at a wide range of output pressure according to the selected system pump. A single NetaFlex™ 3G will accommodate from a 0.1 ha (0.25 acre) to a 10 ha (25 acre) nursery. For output pressure lower than 3.0 bar (44 PSI) consult your local Netafim™ representative.

Fertilizer dosing capacity

The NetaFlex™ 3G accommodates up to 6 dosing channels of various types in many mixed configuration:

- 50 l/h (13 GPH)
- 150 l/h (40 GPH)
- 400 l/h (105 GPH)
- 600 l/h (158 GPH)

* For applications requiring more than 6 dosing channels - consult your local Netafim™ representative.

Basic functions

The NetaFlex™ 3G supports the following Nutrigation™ functions:

- Fully controlled dosing and mixing of fertilizers/acid with source water into a homogenous nutrient solution.
- EC and pH correction of the nutrient solution (single or dual EC and pH control available).

Operating principle

Fertilizers and acid are injected into a tank, opened to the atmosphere; a homogeneous solution is prepared in the tank before it is delivered to the field.

The open mixing tank method permits accelerated assimilation of fertilizers into the water. The result is a perfectly mixed solution.

Service

The NetaFlex™ 3G utilises a modular construction making servicing a simple and prompt process.

The dealer keeps a small quantity of interchangeable components on hand, for replacement on site within a few minutes.

Maintenance

To prevent failures and extend the life cycle of the NetaFlex™ 3G, regular maintenance must be carried out by the user, such as periodic rinsing of filters and calibration of the EC and pH sensors.

Regular maintenance of the NetaFlex™ 3G is a prompt, low cost process requiring no special tools or skills.

DESCRIPTION

Add-ons

You can extend the functionality of your NetaFlex™ 3G by means of the many add-ons offering a wide variety of useful functions. All the add-ons are easy to connect to the NetaFlex™ 3G - here are a few examples:

Fertilizer meter with electric output

Enables continuous reading of fertilizer dosing. Useful in applications where the customer wants a broader indication on fertilizer flow on top of the EC and pH readings.

Stock selection

Enables the dosing of multiple fertilizers through a single dosing channel (in cases where simultaneous dosing is not required).

Available in a wide variety of configurations, from a single channel with 2 fertilizers to as many channels and fertilizers as required.

For further information on the NetaFlex™ 3G add-ons, consult your local Netafim™ representative.

Diagram 1 - Schematic diagram

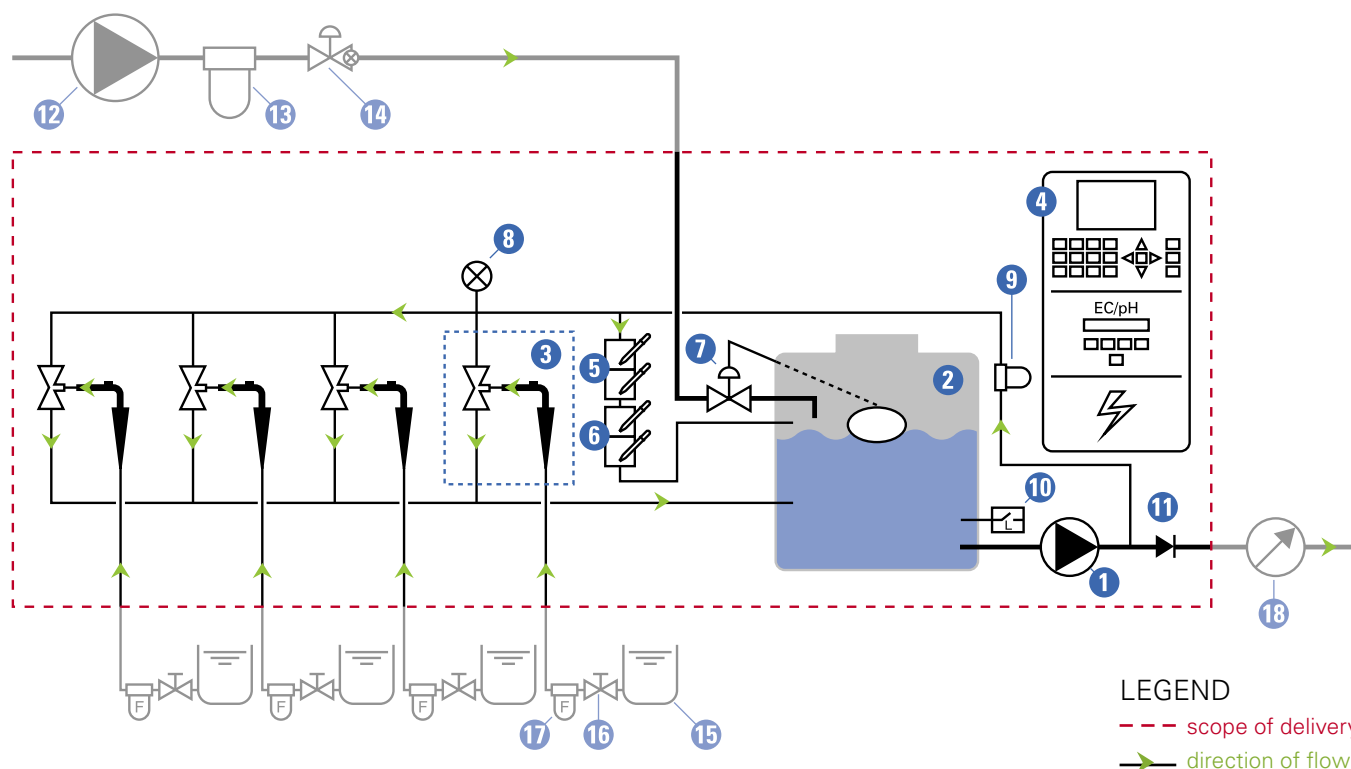

1 System pump

2 Tank

3 Dosing channel + Venturi

4 Control panel, including:
Controller, EC/pH transducer,
electric switchboard.

5 EC sensors (2)

6 pH sensors (2)

7 Float valve

8 Pressure gauge

9 Upper manifold filter

10 Low level switch

11 Non-return valve

12 Filling pump

13 Filling line filter

14 Pressure reducing valve

15 Fertilizer/acid stock tank

16 Manual valve (fertilizer)

17 Fertilizer/acid filter

18 Water meter

LEGEND

--- scope of delivery

→ direction of flow

DESCRIPTION

Fig 1 - Typical installation overview

The drawing below represents a typical NetaFlex™ 3G infrastructure.

NetaFlex™ 3G

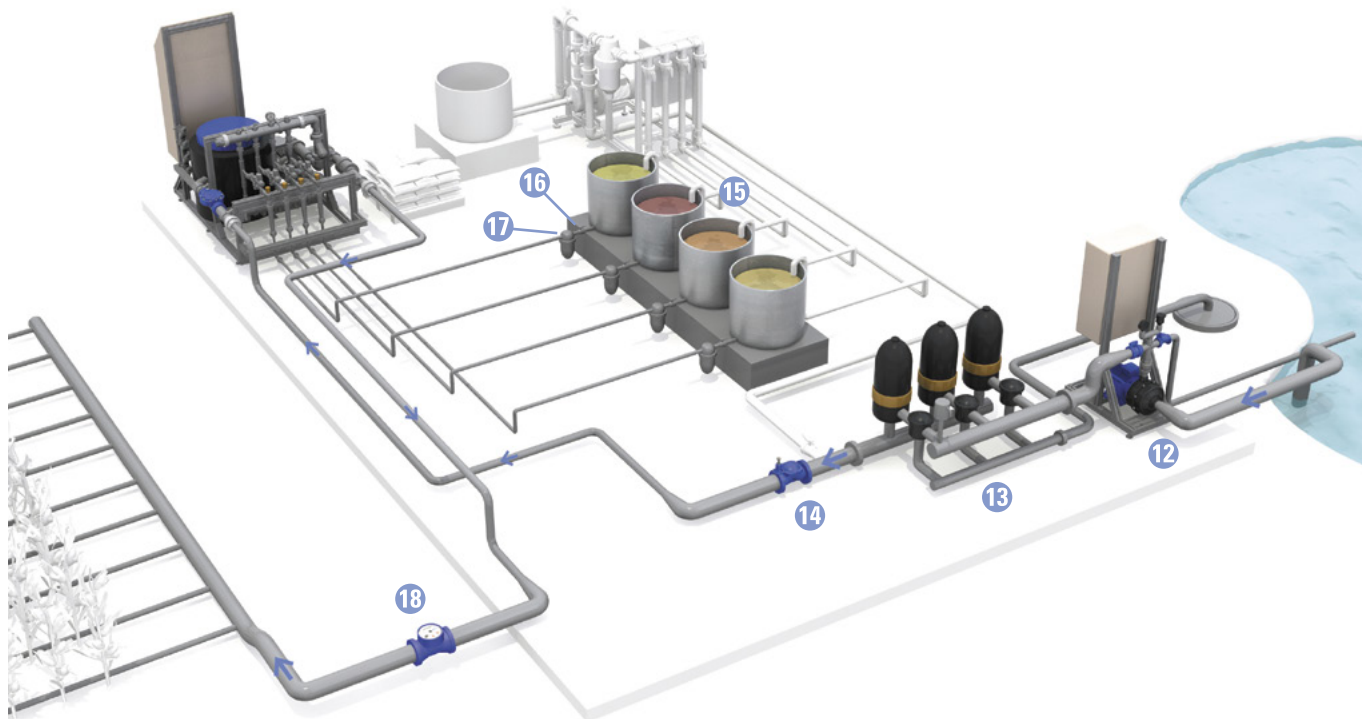
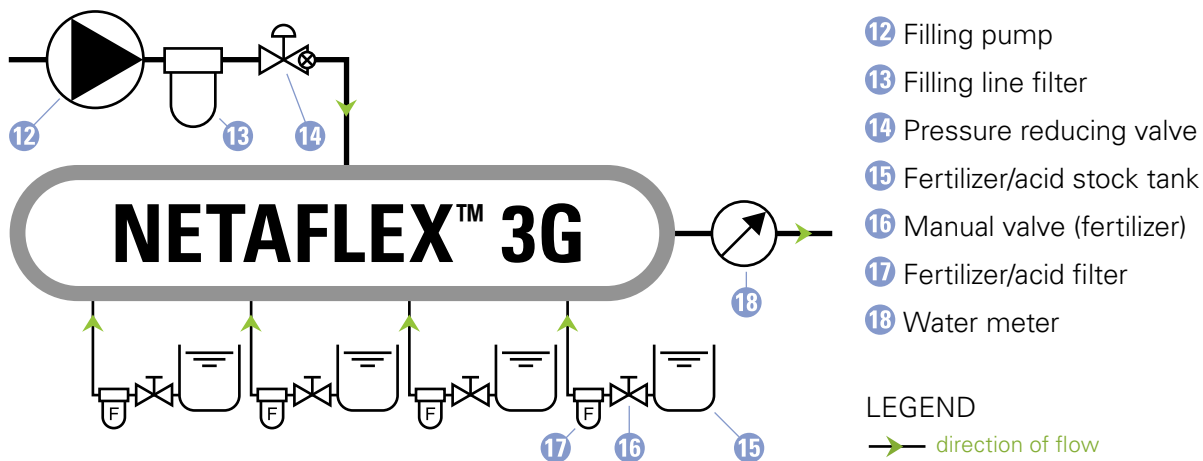

Diagram 2 - Infrastructure schematic diagram



DESCRIPTION

Dimensions

Fig 2 - Extrenal dimensions

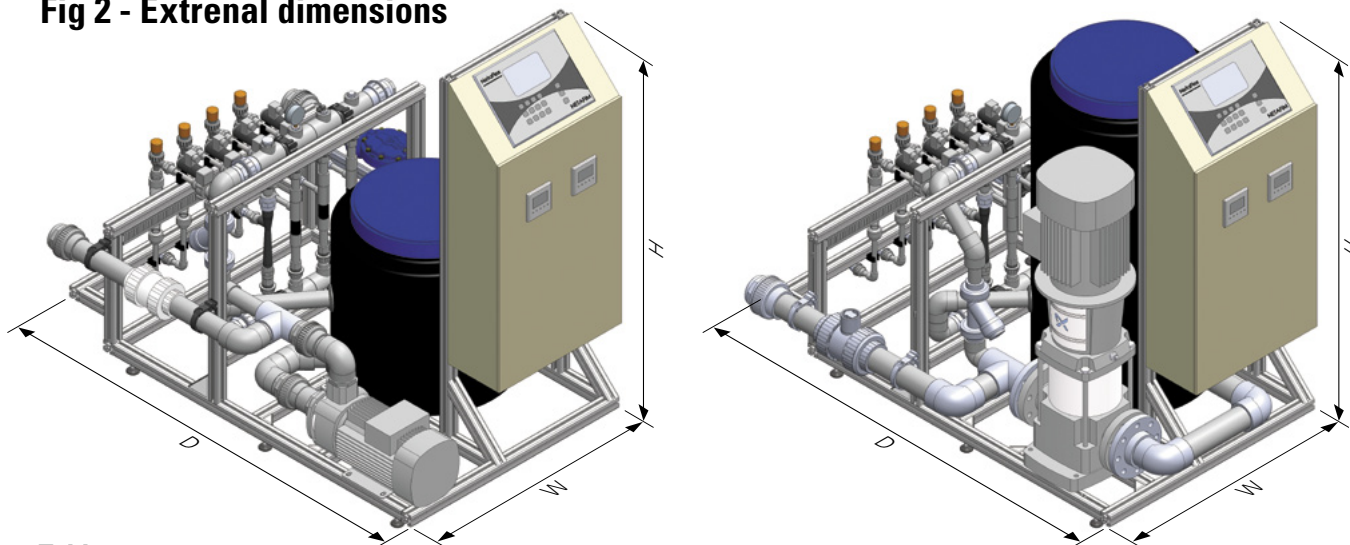

Table 2

NetaFlex™ 3G external dimensions (W/D/H*)	Package dimensions (W/D/H**)
109/148/133.5 cm (43/58.3/52.5")	131/166/159 cm (51.5/65.5/62.5")

*The height varies by ± 1 cm (± 0.5 ") according to the adjustment of the legs.

**The package height includes the pallet height of 15 cm (6").



NOTE

Allow 20 cm (8") around the NetaFlex™ 3G for inlet, outlet and fertilizer pipes connections.

Weights°

The weight of the NetaFlex™ 3G varies according to the selected system pump.

Table 3

50Hz			60Hz		
System pump	Net weight°	Packed weight°	System pump	Net weight°	Packed weight°
CM10-3	156 kg. (344 lbs.)	286 kg. (631 lbs.)	CM10-2	158 kg. (348 lbs.)	288 kg. (635 lbs.)
CM10-4	159 kg. (351 lbs.)	289 kg. (637 lbs.)	CM10-3	161 kg. (355 lbs.)	291 kg. (642 lbs.)
CM15-4	175 kg. (386 lbs.)	305 kg. (673 lbs.)	CM15-2	160 kg. (353 lbs.)	290 kg. (639 lbs.)
CM25-2	153 kg. (337 lbs.)	283 kg. (624 lbs.)	CM25-2	172 kg. (379 lbs.)	302 kg. (665 lbs.)
CM25-3	176 kg. (388 lbs.)	306 kg. (675 lbs.)	CR32-2-2	214 kg. (472 lbs.)	344 kg. (758 lbs.)
CR32-3-2	217 kg. (478 lbs.)	347 kg. (765 lbs.)	CR32-2	226 kg. (498 lbs.)	356 kg. (785 lbs.)
CR32-3	217 kg. (478 lbs.)	347 kg. (765 lbs.)	CR45-2-2	280 kg. (617 lbs.)	410 kg. (904 lbs.)
CR45-2	237 kg. (522 lbs.)	367 kg. (809 lbs.)	CR45-1	233 kg. (514 lbs.)	363 kg. (800 lbs.)
CR45-3-2	284 kg. (626 lbs.)	414 kg. (913 lbs.)	CR64-1	279 kg. (615 lbs.)	409 kg. (902 lbs.)
CR64-2-1	283 kg. (624 lbs.)	413 kg. (911 lbs.)	CR64-2-2	296 kg. (653 lbs.)	426 kg. (939 lbs.)
CR64-2	240 kg. (529 lbs.)	370 kg. (816 lbs.)			

°Order of magnitude only - final weights are issued with the product order.

ON-SITE PREPARATIONS

Hydraulic infrastructure preparation

Before performing the infrastructure installation, consult [Typical installation overview](#), page 12.

Required proportions

To enable optimal operation of the NetaFlex™ 3G, piping must be installed while maintaining the following proportions.

Fig 3

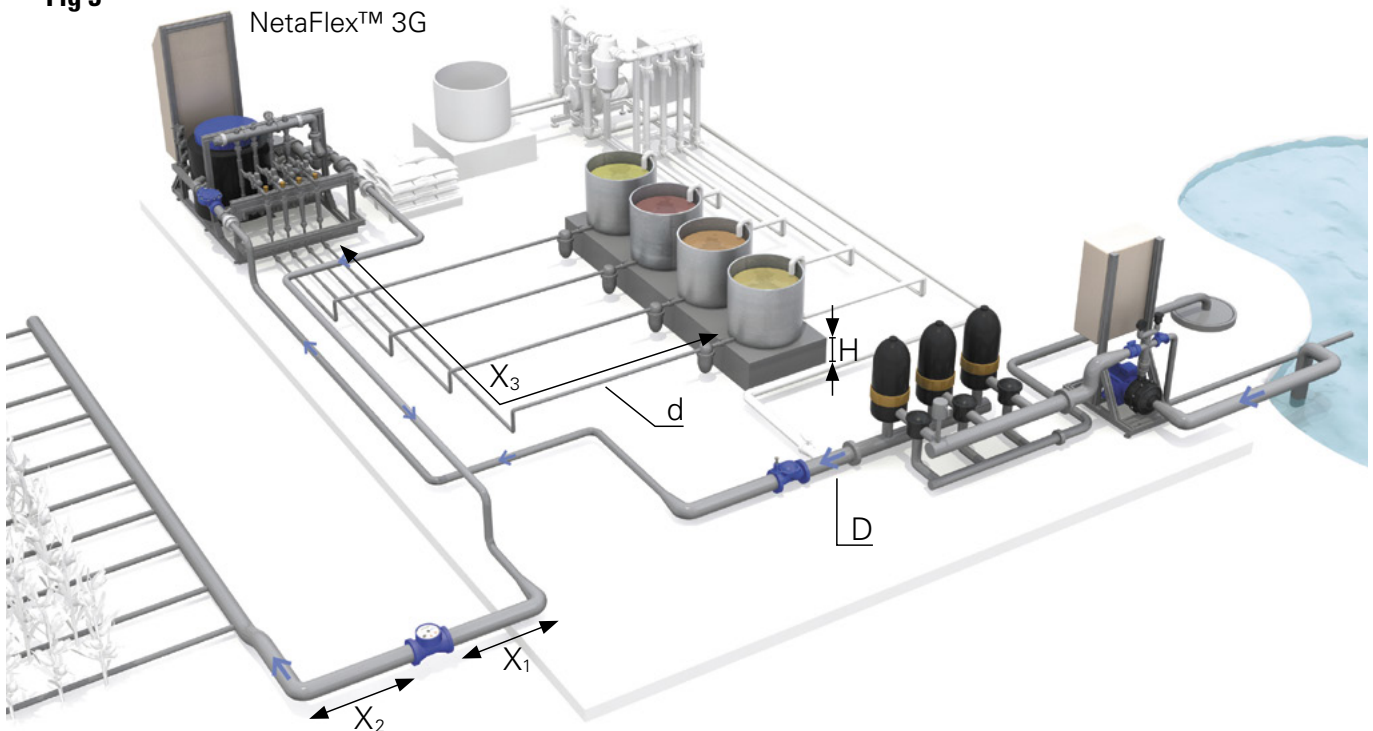

Table 4 - Infrastructure required proportions

Description	Required proportions
D Filling line - pipe diameter	
d Fertilizer/acid lines - pipe diameter: <ul style="list-style-type: none"> • 32 mm (1¼") for dosing channels of up to 400 l/h (106 GPH) • 40 mm (1½") for dosing channels of over 400 l/h (106 GPH) 	
X ₁ Length of the pipe upstream from the water meter to the adjacent corner <ul style="list-style-type: none"> • Pipe must be straight 	10 x D
X ₂ Length of the pipe downstream from the water meter to the adjacent corner <ul style="list-style-type: none"> • Pipe must be straight 	5 x D
X ₃ Length of fertilizers or acid lines	Max. 10 meter (33 feet)
H Elevation of the fertilizer/acid tanks	Min. 30 cm (12")

Filling line flow rate and pressure requirements

In order to enable the NetaFlex™ 3G operation, the following requirements must be met.

- Source water should enter the NetaFlex™ 3G at a flow rate equal to the maximum flow rate required for the field.

If the flow rate at the inlet of the NetaFlex™ 3G is insufficient, the low level switch will be activated and the NetaFlex™ 3G operation will be stopped.

ON-SITE PREPARATIONS

- The water entering the NetaFlex™ 3G should be within a pressure range of 2 to 4.5 bar (29 PSI to 65 PSI).



NOTE

To ensure flow rate stability, the consumption of the individual irrigation shifts should be as equal as possible. Each changeover between shifts with different consumption will result in consumption fluctuation that will affect the EC and pH stability. The consumption of the smallest shift should not be less than 75% of the consumption of the largest shift.

Pump house (Filter house / Fertilizer house) requirements



CAUTION

The NetaFlex™ 3G should:

- be placed in a weather protected environment;
- be placed in a roofed building;
- not be exposed to direct sunlight;
- be properly ventilated;
- be protected from dust;
- be placed in an environment with pollution not exceeding degree 3;
- be at an altitude up to 2,000 m (6560 ft);
- be kept at an ambient temperature between 5°C and 40°C (41°F and 104°F);
- be kept at a maximum relative air humidity of 80% for temperatures up to 31°C (88°F), decreasing linearly to 50% relative humidity at 40°C (104°F); or as necessary for correct function;
- be protected from splashes or direct spraying with water or chemicals;



NOTE

In order to prevent penetration of fertilizer or acid to the soil, it is recommended that the floor of the pump house have a slope of minimum 1% towards a gutter at its lower edge and an underground tank at the lower end of the gutter, enabling drainage of any spill or excess.

Location of inlet, outlet and fertilizer/acid line connectors

The location of the inlet and the outlet connectors vary according to the selected system pump.

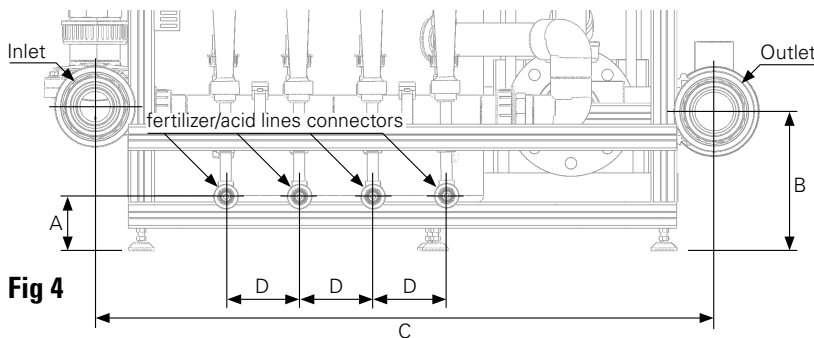

Table 5

System pump	Distance - cm (inch)			
	A*	B*	C	D
CM10	12.5 cm (4.9")	36.6 cm (14.4")	95.7 cm (37.7")	11.4 cm (4.5")
CM15				
CM25				
CR 32		15.8 cm (6.2")	97.5 cm (38.4")	
CR 45		18.3 cm (7.2")		
CR 64				

*The height varies by ±1 cm (±0.5") according to the adjustment of the legs.

ON-SITE PREPARATIONS

The water distribution system

For the setup of the water distribution system the following components should be installed:

Table 6 - Components of the water distribution system

Component	Specifications
12 Filling pump	Suitable for flow rate satisfying the maximum field requirement (Ensure stable pressure).
13 Filling line filter	≤ 130 μm (≥ 120 mesh).
14 Pressure reducing valve (PRV)	Should be installed on the filling line, downstream from the filling line filter and be able to supply suitable pressure as specified for the NetaFlex™ 3G.
15 Fertilizer/acid stock tank	Between 1 and 6 fertilizer/acid solution stock tanks
16 Manual valve (fertilizer)	A manual ball valve on each fertilizer/acid line at the stock tank outlet
17 Fertilizer/acid filter	≤ 130 μm (≥ 120 mesh)
18 Water meter	With electrical pulses. The pulse should be as short as possible according to the output line diameter and the controller's limitations. (See Recommended flow meter, table 8 below.)



CAUTION

EC and pH sensors must never be exposed to pressure greater than 6 bars (87 PSI).

Table 7 - Recommended flow meter pulse rate

Flow rate m ³ /h	Flow meter output l/pulse	Flow rate GPM	Flow meter output US gal/pulse
Up to 6	1	Up to 88	1
6 - 60	10	88 - 1000	10

The fertilizer/acid tanks and lines

For the setup of the fertilizer/acid tanks and lines, the following components should be installed:

Table 8 - Components of the fertilizer/acid tanks and lines

Component	Specifications
15 Fertilizer/acid stock tank	Between 1 and 6 fertilizer/acid solution stock tanks
16 Manual valve (fertilizer)	A manual ball valve on each fertilizer/acid line at the stock tank outlet
17 Fertilizer/acid filter	≤ 130 μm (≥ 120 mesh)

The following aspects should be taken into account:

- Ensure the stock tanks are of sufficient size for storage of at least one day's consumption .
- Sufficient space should be available between the fertilizer/acid tanks and the NetaFlex™ 3G, to enable inspection and maintenance operations.
- Fertilizer/acid pipe diameter: 32 mm (1¼") for dosing channels of up to 400 l/h (106 GPH)
40 mm (1½") for dosing channels of over 400 l/h (106 GPH)
- For the connection of fertilizer supply lines to the NetaFlex™ 3G, use a transparent, chemical-resistant, reinforced PVC water hose with an internal diameter of 16 mm that will not contract when there is a vacuum in the system.
- Use properly sealing stainless steel band clamps for the fertilizer/acid hose connection, type SS 316.

ON-SITE PREPARATIONS



CAUTION

After completion of the hydraulic infrastructure, before the installation of the NetaFlex™ 3G, rinse the hydraulic infrastructure and fertilizer/acid lines and tanks by running water through them in order to wash away any residues (chips, shavings, sawdust) due to the setup work.

Electrical preparation

Mains connection



CAUTION

Only qualified electricians are permitted to perform electrical installations!



ATTENTION

Make sure the electrical supply capacity is in accordance with the electrical characteristics of the NetaFlex™ 3G.

Make sure the short-timed higher current consumption when starting up the system pump was taken in consideration (for further details see the enclosed Pump Documentation).

The following components have to be provided in the installation:

- A readily accessible automatic circuit breaker, rated according to the NetaFlex™ 3G's total rated power for peak demand, certified as a branch circuit over-current protector (see [Appendix 2 - System Pump List](#), page 35), compliant with the national code and requirements.
- Grounding connection: $\leq 10 \Omega$.
- The electrical power cord to be selected and installed by a qualified electrician in accordance with equipment ratings and with cord EU harmonized certifications and local regulatory requirements.
- Cord is to be permanently field Installed into the end-user branch circuit cabinet.
- Branch circuit of residual current device for human protection - 30 mA.



ATTENTION

- MAINS supply voltage fluctuations must be lower than $\pm 10\%$ of the nominal voltage;
- TRANSIENT OVERVOLTAGES up to the levels of OVERVOLTAGE CATEGORY II
- TEMPORARY OVERVOLTAGES occurring on the MAINS supply.

For the selection of the supply wire size - consider (see [Appendix 2 - System Pump List](#), page 35):

- The NetaFlex™ 3G's total rated power.
- Whether the electricity supply is single-phase or three-phase.

Table 9 - Mains wire size for three-phase system*

5 wires: GND, N, L1, L2, L3

Power source required (kWatt)	3 X 200-250 VAC	3 X 400-480 VAC
Up to 1.5	$\geq 2.5 \text{ mm}^2 (\leq 13 \text{ awg})$	$\geq 2.5 \text{ mm}^2 (\leq 13 \text{ awg})$
1.5-2		
2-3	$\geq 4 \text{ mm}^2 (\leq 11 \text{ awg})$	$\geq 2.5 \text{ mm}^2 (\leq 13 \text{ awg})$
3-4		
4-6	$\geq 6 \text{ mm}^2 (\leq 9 \text{ awg})$	$\geq 4 \text{ mm}^2 (\leq 11 \text{ awg})$
6-8	$\geq 10 \text{ mm}^2 (\leq 7 \text{ awg})$	
8-10	$\geq 16 \text{ mm}^2 (\leq 5 \text{ awg})$	$\geq 6 \text{ mm}^2 (\leq 9 \text{ awg})$
10-12		$\geq 10 \text{ mm}^2 (\leq 7 \text{ awg})$
12-16	$\geq 25 \text{ mm}^2 (\leq 3 \text{ awg})$	

*Using a cable not longer than 25 meter (82 feet) between the power supply and the switchboard of the NetaFlex™ 3G.

INSTALLATION

Unpacking and placement

Check the ShockWatch label attached to the packaging and ensure the indicator is white. If the indicator is red - act according to the instruction on the ShockWatch label.

Place the NetaFlex™ 3G package close to the irrigation system using forklift.

Gently open the packaging.

Remove the 4 screws and bolts connecting the NetaFlex™ 3G to the wooden pallet.

Remove plastic cover from controller (if existing).

Place the NetaFlex™ 3G in its position.

Adjust the legs so that the NetaFlex™ 3G is steady.



Fig 5

Hydraulic installation



WARNING

When handling fertilizers, acid and other chemicals, always use protective equipment, gloves and goggles.

NetaFlex™ inlet/outlet connection

Connect the appropriate pipes to the inlet and the outlet of the NetaFlex™ 3G (see [Location of inlet, outlet and fertilizer/acid line connectors](#), page 15).

Table 10 - Two types of connectors are supplied

System pump	Diameter - mm (inch)	
	PVC, adaptor union - glue connector (installed)	BSP or NPT nipple - male thread connector (supplied)
CM10	63 mm	2"
CM15		
CM25		
CR 32	75 mm	2.5"
CR 45		
CR 64	90 mm	3"

INSTALLATION

Stock tank connection

Connect the fertilizer lines to the NetaFlex™ 3G
(see [Location of inlet, outlet and fertilizer/acid line connectors](#), page 15).

Table 11 - Three types of connection are available

Fittings (interchangeable)	Diameter
PVC, hose nozzle insert connector (installed)	16 mm
PVC, nipple - male thread connector (supplied)	1/2"
PVC, half union - female thread connector (supplied)	3/4"

Prior to flexi-tube connection, thread a stainless steel band clamp **A** on each flexi-tube hose.

Heat the tip of each Flexi tube hose in boiling water to make it flexible for insertion.

Connect flexi-tube hose from fertilizer lines to the hose-nozzle-insert connectors of dosing channels **B**, ensuring 0.5 meter (1.7 feet) of transparent, chemical-resistant, reinforced PVC water hose with an internal diameter of 16 mm that will not contract when there is a vacuum in the system.

Attach the stainless steel band clamp on each flexi-tube connection **C** and secure tightly.

Flexi-tube specification:

- 16 mm (1/2") reinforced EVA tubing.
- Material: EVA (ethylene vinyl acetate) tube compound specially formulated to meet USDA requirements.
- Polyester cord reinforcement with color tracer.
- Pressure: 18 to 20 Bar (250 to 300 PSI).
- Recommended temperature range:
-23°C to +65°C (-10°F to +150°F).



TIP

You can rotate the hose connectors of the dosing channels to face the desired direction according to the location of the stock tanks.

Loosen the Rotameter's lower connector **A**, rotate the hose connector to the desired direction **B** and fasten the Rotameter's lower connector **A**.

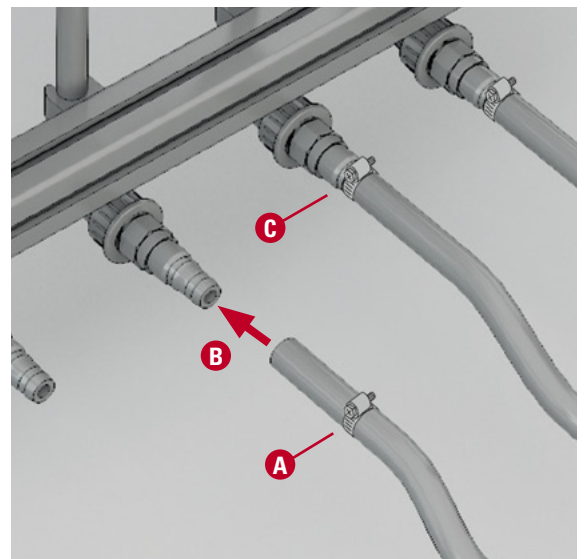

Fig 6

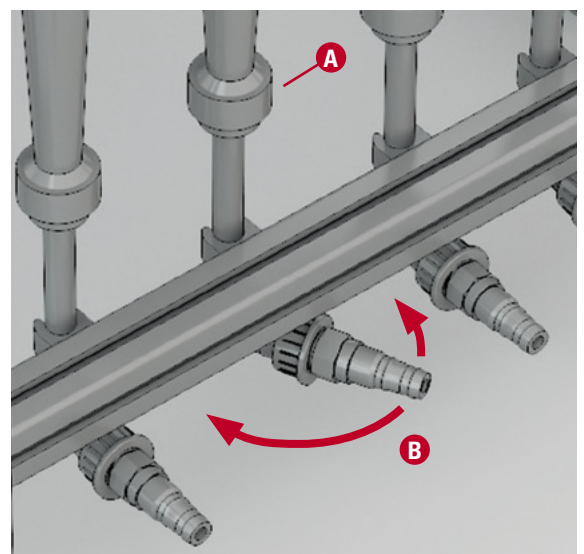

Fig 7

INSTALLATION

Dual dosing channel

If the NetaFlex™ has more than 4 dosing channels (up to 6), the dual dosing channel option is utilized.

- Up to 2 dual dosing channels are installed on the NetaFlex™ 3G, at the farthest manifold positions (1 and 4).
- The dual dosing channel option is applicable with 600 l/h (158 GPH) or 50 l/h (13 GPH) Venturis.

Diagram 3 - Dual dosing channels schematic diagram

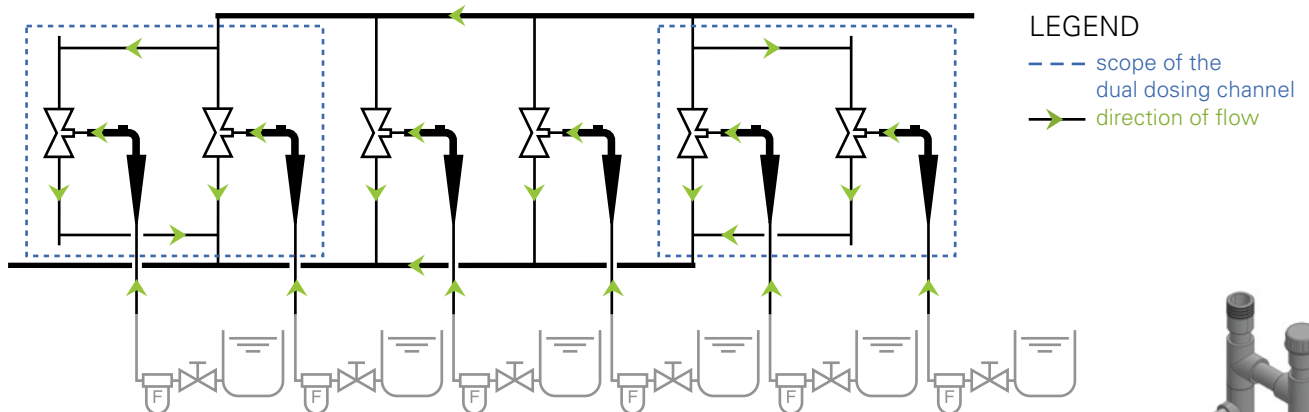

CAUTION

There are fertilizer combinations that should never be used in the dual dosing channel as they will induce crystallization and cause clogging of the pipes.

- Calcium Nitrate + Ammonium Sulfate => Calcium Sulfate
- Calcium Nitrate + Potassium Sulfate => Calcium Sulfate
- MKP + Calcium Nitrate => Calcium Phosphate
- MAP + Calcium Nitrate => Calcium Phosphate
- Phosphoric acid + Calcium Nitrate => Calcium Phosphate

In case of doubt regarding the use of any combination of fertilizers in the dual dosing channel, consult your local Netafim™ representative.

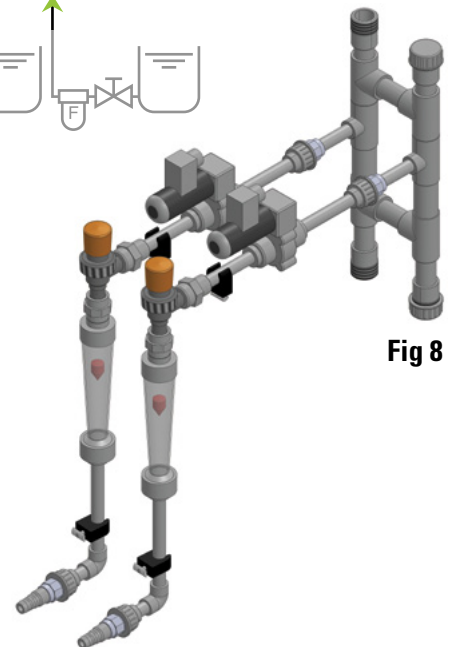

Fig 8

Electrical installation



CAUTION

Only qualified electricians are permitted to perform electrical installations!

Have a qualified electrician connect the NetaFlex™ 3G to the mains.

Follow the instructions in the enclosed Switchboard Documentation.



ATTENTION

The key to the electrical cabinet is to be in the possession of the service personnel and not of the operator.

SYSTEM OPERATION



NOTE

The following procedure describes the operations that should be performed, regardless of the type of controller in use. For the operation of the specific controller interface, see the Controller Manual.

Preparations for running the NetaFlex™ 3G

For NetaFlex™ 3Gs with an onboard or external controller:

Run the controller and enter preliminary general settings (see the Controller Manual).

Ensure that the INPUT for protection against low level in the mixing tank is connected to the controller and defined (see the Controller Manual).

Connect all the elements (valves, pumps, filters, sensors, etc.) to the controller (see the Controller Manual).

Manual test of controller outputs

Perform the test to make sure that all the elements (valves, pumps, filters, sensors, etc.) function properly upon command from the controller.

Run the test using the controller's TEST menu (see the Controller Manual).

Set the relay status of the dosing channels to MANUAL and make sure that the irrigation program is not defined (see the Controller Manual).



NOTE

Make sure the dosing valve selector is in the CLOSED position.

To check that the dosing channels are working:

When the OPEN command from the controller is given - the LED on the dosing valve is lit.

Calibration of sensors

Calibrate the EC and pH sensors (see the EC/pH Transducer Manual).



ATTENTION

Unions tend to get loose during transit.

Before operating the NetaFlex™ 3G, tighten all the unions of the NetaFlex™ 3G by hand.

Filling the NetaFlex™ 3G with water for the first time



CAUTION

When opening or closing any manual valve, always do it gradually, to prevent damage to the system by water hammer.

Gradually fill the NetaFlex™ 3G with water until the float valve closes.

If the float valve does not close the tank may overflow - immediately stop filling the tank and check the float valve for fault)

Keep the system under static pressure for 10 minutes and visually check for leaks in the filling line.

Verify that the arm of the float remains horizontal (The water level in the tank is kept).

Perform a simulation test with a 10 liter (2 gallons) bucket of water. (see [Appendix 1 - Calibration](#), page 24)



Fig 9

SYSTEM OPERATION

Check the system pump operation



CAUTION

Only qualified electricians are permitted to perform electrical installations and repairs!

Switch the system pump ON for a few seconds and check that it is rotating in the correct direction. If the pump does not rotate in the correct direction - a qualified electrician should swap between phases L1 and L3 (see the system pump Manual).



HIGH VOLTAGE ELECTRICAL HAZARD

Before unplugging the system from the main power source, switch the unit and the main power source OFF!

Running the NetaFlex™ 3G

Define a program in the controller for one valve or multiple valves (shift) as defined by the irrigation plan (see the Controller Manual).

In the first stage it is recommended that you define a program with quantitative or proportional fertigation only, without EC/pH control (see the Controller Manual).

Temporarily deactivate all alarms in the system - EC/pH, flow control, etc. (see the controller manual).

Start the program and wait for the lines to be filled (this takes a few minutes, depending on the size of the installation).

Check that the flow rate displayed on the controller's screen and the pressure at the system outlet displayed on the pressure gauge are stabilized (see the Controller Manual).

Make sure flow rate and pressure are in range according to the performance curve of the relevant system pump (see Sales Documentation, page 10).

If the system cannot reach the required flow rate and pressure, it is possible that there is an air pocket in the system pump's impeller chamber:

Loosen the system pump's bleeding screw and wait until a stable flow, free of air bubbles, is obtained, then retighten the bleeding screw (see the System Pump Manual).

Check the suction of the dosing channels from the stock tanks, and tune the desired flow rate for each dosing channel by adjusting the needle valve (see [Calibration of the dosing unit while irrigating](#), page 26).

Let the system run for about ten minutes and see that it works properly.

check for leaks in the NetaFlex™ 3G and the infrastructure.

After tuning the flow rate for each dosing channel, adjust the cursors on each Rotameter (Fig 10).

Fig 10

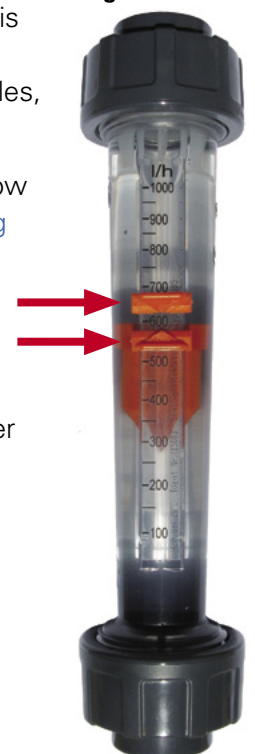

SYSTEM OPERATION



NOTE

The Rotameter's scale is calibrated by the manufacturer for measurement of the flow rate of water (H₂O). Certain inaccuracies may be observed when the flow rate of liquids with different densities, such as fertilizers and acids, is measured.

Measure the EC and pH control cycle

- EC and pH control cycle is the time elapsed from the start of fertilizer or acid injection until the change starts to be recorded by the EC and pH transducer (usually 4-10 sec.).

To measure the NetaFlex™ 3G control cycle for pH*:

Run the NetaFlex™ 3G with fresh water only until the pH value stabilizes on the transducer's display (Deviation not greater than +0.1 -0.1).

Manually open the acid dosing channel and simultaneously start a timer.

Observe the pH value on the transducer's display, as soon as it first reacts stop the timer.

We recommend to repeat the 3 previous steps 3 times and calculate the average time.

Enter the data into the controller (**NMC Pro - screen 7.7**).

Stop the program.

*Time aplicable for EC and pH control cycle.



ATTENTION

Restore the settings of all the alarms back to the state where adequate protection to the system and the crop is provided (see the Controller Manual).

If there is any problem during the process, see Troubleshooting in the NetaFlex™ 3G User Manual.

CALIBRATION

The process of calibrating the NetaFlex™ 3G is carried out in three stages:

1. Calculation of dosing channels opening percentage

To finely calibrate the NetaFlex™ 3G in order to achieve homogeneous and stable dosing, perform the following calculation for each dosing channel (fertilizers and acid) to determine the amount of suction reduction needed to attain the required fertilizer/acid flow rate.

Metric units

Flow rate of the largest irrigation shift m³/h
 X
 Dosing ratio of a single fertilizer/acid l/m³
 =
 Result: a single fertilizer/acid flow rate l/h
 X 1.25 =
 Result: target Rotameter reading l/h

EXAMPLE

m³/h
 X
 l/m³
 =
 l/h
 X 1.25 =
 l/h

DEFINITION

Dosing ratio = $\frac{\text{The quantity of fertilizer/acid (l)}}{1 \text{ m}^3 \text{ irrigation water}}$

US units

Flow rate of the largest irrigation shift GPM
 X
 Dosing ratio of a single fertilizer/acid US gal/1000 US gal
 X 0.06 =
 Result: a single fertilizer/acid flow rate GPH
 X 1.25 =
 Result: target Rotameter reading GPH

EXAMPLE

GPM
 X
 US gal/1000 US gal
 X 0.06 =
 GPH
 X 1.25 =
 GPH

DEFINITION

Dosing ratio = $\frac{\text{The quantity of fertilizer/acid (US gal)}}{1 \text{ THG (1000 US gal) irrigation water}}$



NOTE

The Rotameter's scale is calibrated by the manufacturer for measurement of the flow rate of water (H₂O). Certain inaccuracies may be observed when the flow rate of liquids with different densities, such as fertilizers and acids, is measured.

2. Simulation test with a 10 liter (2 US gal) bucket of water

Instruments needed

- Good-quality portable EC and pH sensors, finely calibrated
- Calibration solutions for EC and pH
- Bucket with a scale for up to 10 liters (2 US gallons)
- Measuring tube or syringe with a scale for up to 100 cc (1 oz)
- Clean (preferably distilled) water for cleaning sensors during calibration
- Blotting paper for cleaning and drying

The client prepares the fertilizer solutions and the acid solution (if required) in the stock tanks according to the recipe advised by the agronomist/consultant.



ATTENTION

Ensure the fertilizers and acid solutions in the stock tanks have been thoroughly agitated before starting the simulation.

CALIBRATION

Note the required dosing ratio of each fertilizer solution and the dosing ratio of the acid solution (if used).
 Fill a bucket with 10 liters (2 US gallons) of the client's supply water (without fertilizer or acid).
 Measure the EC and the pH levels of the water in the bucket using calibrated portable sensors.

EXAMPLE

	EC	pH
Supply water (without fertilizer or acid)	0.3	7.8

Using a measuring tube or a syringe, take a dose from each fertilizer solution and from the acid solution (if used) according to the proportions determined by the dosing ratio (see example below) and **mix thoroughly** with the water in the bucket.

EXAMPLE

Metric units

For a fertilizers dosing ratio of 10 l/m³ each and an acid dosing ratio of 2 l/m³ the quantities for 10 liters of water in the Bucket-simulation-test will be 100 cc of each fertilizer solution and 20 cc of the acid solution

US units

For a fertilizers dosing ratio of 3.0 US gal/THG each and an acid dosing ratio of 1.1 US gal/THG the quantities for 2 US gallons of water in the Bucket-simulation-test will be 0.76 oz* of each fertilizer solution and 0.28 oz** of the acid solution

DEFINITIONS

1 US gal = 128 oz

$$* \frac{3.0 \times 2}{1000} = 0.006 \text{ US gal} = 0.768 \text{ oz}$$

$$** \frac{1.1 \times 2}{1000} = 0.0022 \text{ US gal} = 0.28 \text{ oz}$$

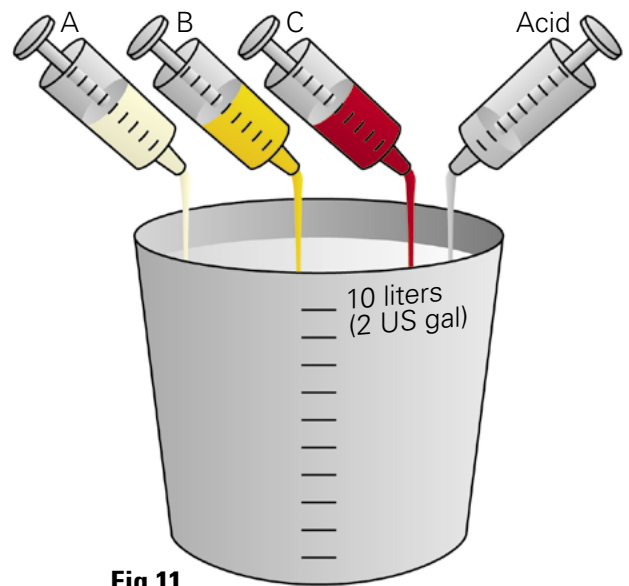

Fig 11

Measure the EC and the pH levels of the mixture in the bucket using calibrated portable sensors.
 Compare the measured EC and pH values to the target values set by the agronomist/consultant.

EXAMPLE

	EC	pH
After adding the fertilizers and acid	1.6	5.5
Target values	1.8	5.8
Deviation from target value	11%	5%



Fig 12

CALIBRATION

With the controller set to operate according to EC/pH values - if the EC and pH values measured in the bucket are within a range of $\pm 30\%$ deviation from the target values, the system will be able to correct them automatically.

If the values are out of the $\pm 30\%$ range, check the data and consult the agronomist/consultant.

3. Calibration of the NetaFlex™ 3G while irrigating



WARNING

Extreme EC or pH values may damage the crop.

Perform the following procedure only after completing stage 2 above (Simulation test with a 10 liter or 2 US gallon bucket of water) with satisfactory results.



NOTE

The following steps explain the operations to be performed, regardless of the type of controller used. For the operation of your controller's interface, consult the Controller Manual.

However, since the NMC Pro controller is widely used - its interface screens for the execution of each step are noted.



NOTE

Before the calibration, confirm that the EC and the pH sensors of the NetaFlex™ 3G have been calibrated according to the instructions in the EC/pH Installation Manual.

Define the dosing configuration, while the EC and pH controls are in the OFF position (**NMC Pro - screen 7.7**).

In the EC and pH alarm definitions, set the EC and pH alarm to the OFF position (deactivated) (**NMC Pro - screen 3.6**).

Enter the data for the irrigation valves, and the dosing ratio for each dosing channel (**NMC Pro - screens 1.1-1.2-1.3**).

Run the program (**NMC Pro - screen 2.2**).

Allow a few minutes for the pipes to fill up and the flow rate to stabilize.

Reduce the suction of the dosing channels by adjusting the manual needle valve of each dosing channel until the "target Rotameter reading" calculated in stage 1 (page 24) is attained.



NOTE

The Rotameter's scale is calibrated by the manufacturer for measurement of the flow rate of water (H₂O). Certain inaccuracies may be observed when the flow rate of liquids with different densities, such as fertilizers and acids, is measured.

Check the appropriate controller screen for the measured EC and pH values (**NMC Pro - hot screen 4**).

If the desired values have been reached, check opening percentages of the dosing valves.

The EC and pH target values should be attained with the dosing valves opened to 50% - 80% of their capacity.

If the EC and pH target values are attained with the dosing valves opened less than 50%, reduce the dosing channel suction rate, until the EC and pH target values are reached.



NOTE

Every change in the flow rate of the needle valve must be updated afterwards in the controller (**NMC Pro - screen 7.6**).

CALIBRATION

If the EC and pH target values cannot be attained, and the dosing valves are opened more than 85%, measures should be taken to increase the dosing ratio - if feasible, slightly increase the concentration of the fertilizer solution and/or reduce the water flow rate to the field during irrigation.

If not - consult the agronomist/consultant.

In a field where the flow rate changes significantly from one irrigation shift to the next, try to be at a minimum of 50% dosing valve opening for the low flow rate shift, and a maximum of 80% for the high flow rate shift.

When the calibration process is completed, return to the EC and pH control screen in the controller, define the deviation in EC and pH values for the channels and switch the EC and pH control to ON

(NMC Pro - screen 7.7-7.6).

In the EC and pH alarm definitions, define the EC and pH deviation from the target values that, if attained, will trigger the alarm and set the EC and pH alarm to the ON position (activated) **(NMC Pro - screen 3.5-3.6).**



NOTE

EC and pH values must not exceed a $\pm 30\%$ deviation from the target values.



ATTENTION

Once a month, read the measured flow rates of the dosing channels and compare them with the flow rates defined in the controller, in order to check whether changes have occurred

(NMC Pro - screen 7.6).

After completing the calibration process, write down the data as reference for calibration of the NetaFlex™ 3G in the future.

COMMISSIONING

After completing the calibration process, the NetaFlex™ 3G is ready for commissioning.

Familiarize the client with the NetaFlex™ 3G, the user manual and the accompanying documents and emphasize the following points:

- The importance of following all the safety instructions (see User Manual, pages 6-7).
- The warranty and its restrictions (see User Manual, page 21).
- Calibration - accompany the client through this chapter and emphasize the importance of thorough knowledge of the processes in it for the current operation of the NetaFlex™ 3G (see User Manual, page 22).
- Proper dissolving of fertilizers for optimal utilization of the dosing channels' capacity (see User Manual, page 22).
- The importance of regular maintenance and its impact on the warranty (see User Manual, page 14).
- The importance of periodically comparing the hydraulic data with the initial settings in the controller (see User Manual, page 15).
- Troubleshooting - accompany the client through this chapter (see User Manual, pages 16-20).
- Instruct the client to regularly keep track of the NetaFlex™ 3G Hydraulic Conditions for future reference.

WARRANTY

Netafim™ warrants all the components of the NetaFlex™ 3G to be free of defects in material and workmanship for 1 (one) year from the date of installation, provided the installation has been reported to Netafim™ within 30 days of installation.

If the installation was not reported or was reported later than 30 days from the date of installation, Netafim™ will warrant the NetaFlex™ 3G for a period of 18 months from the date of production, according to its serial number.

If a defect is discovered during the applicable warranty period, Netafim™ will repair or replace, at its discretion, the product or the defective part.

The above does not apply to EC and pH sensors, since they are wearable. Netafim™ will warrant these items to be free of defects in material and workmanship for 3 months from the date of installation, provided the installation has been reported to Netafim™ within 30 days, or 6 months from date of production if installation was not reported or was reported later than 30 days from the date of installation.



CAUTION

When not installed, the pH sensor must be immersed in KCL solution (supplied with the sensor) or in calibration buffer 4 at temperature 18-25°C (64-77°F), protected from freezing and not be exposed to pressure greater than 6 bars (87 PSI).

Damage due to these causes is not covered by warranty.

This warranty does not extend to repairs, adjustments or replacements of a NetaFlex™ 3G or part that results from misuse, negligence, alteration, force majeure, lightning, power surge, improper installation or improper maintenance.

If a defect arises in your Netafim™ product during the warranty period, contact your local Netafim™ representative.

Limited warranty

This warranty is subject to the conditions in Netafim's official warranty statement. (For the full text of Netafim's official warranty statement, please contact your local Netafim™ representative).

APPENDIX 1 - NetaFlex™ 3G PARTS LIST

Fig 13 - 100 L - Horizontal Pump

See Parts list, table 12, page 32

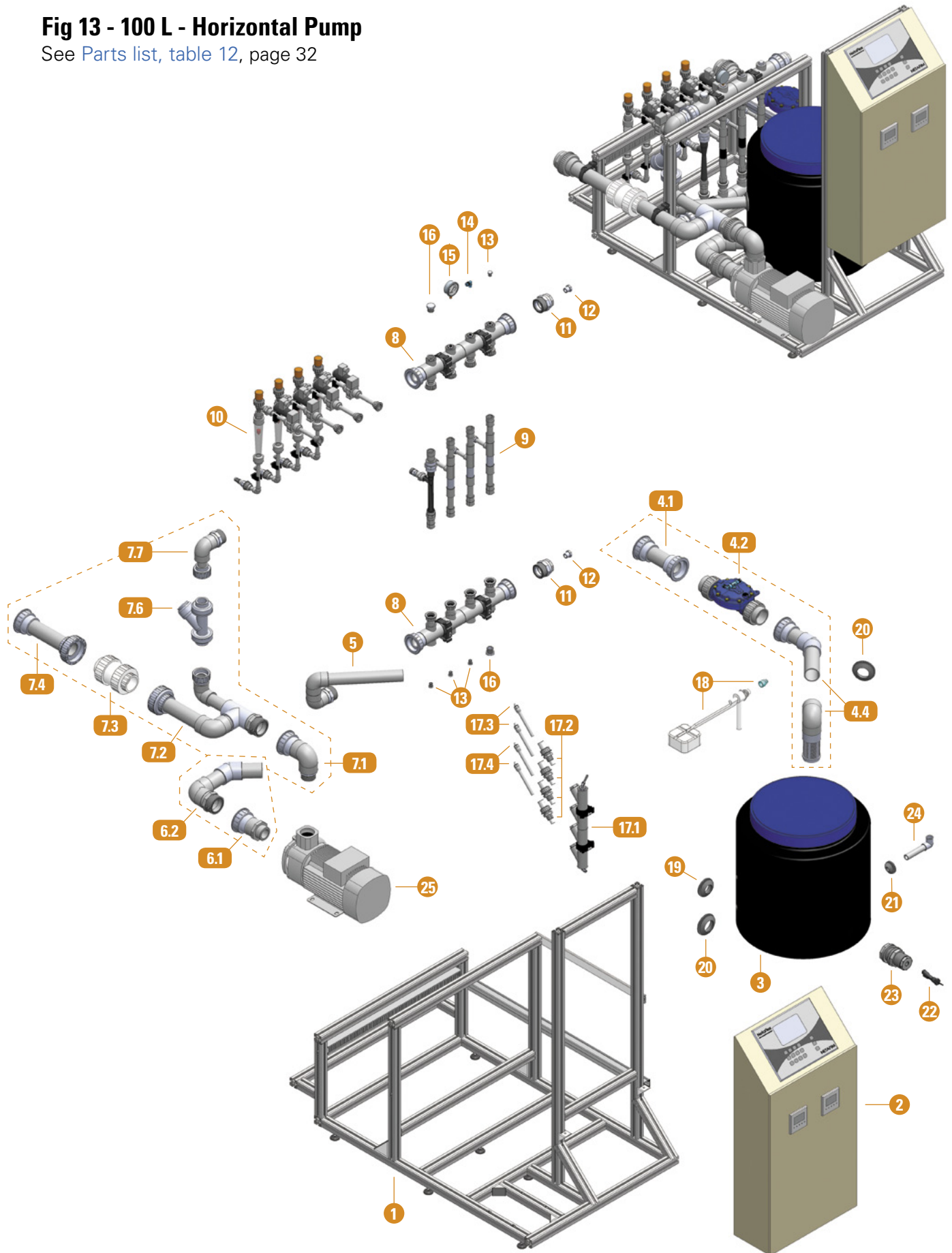

APPENDIX 1 - NetaFlex™ 3G PARTS LIST

Fig 14 - 200 L - Vertical Pump

See Parts list, table 12, page 32

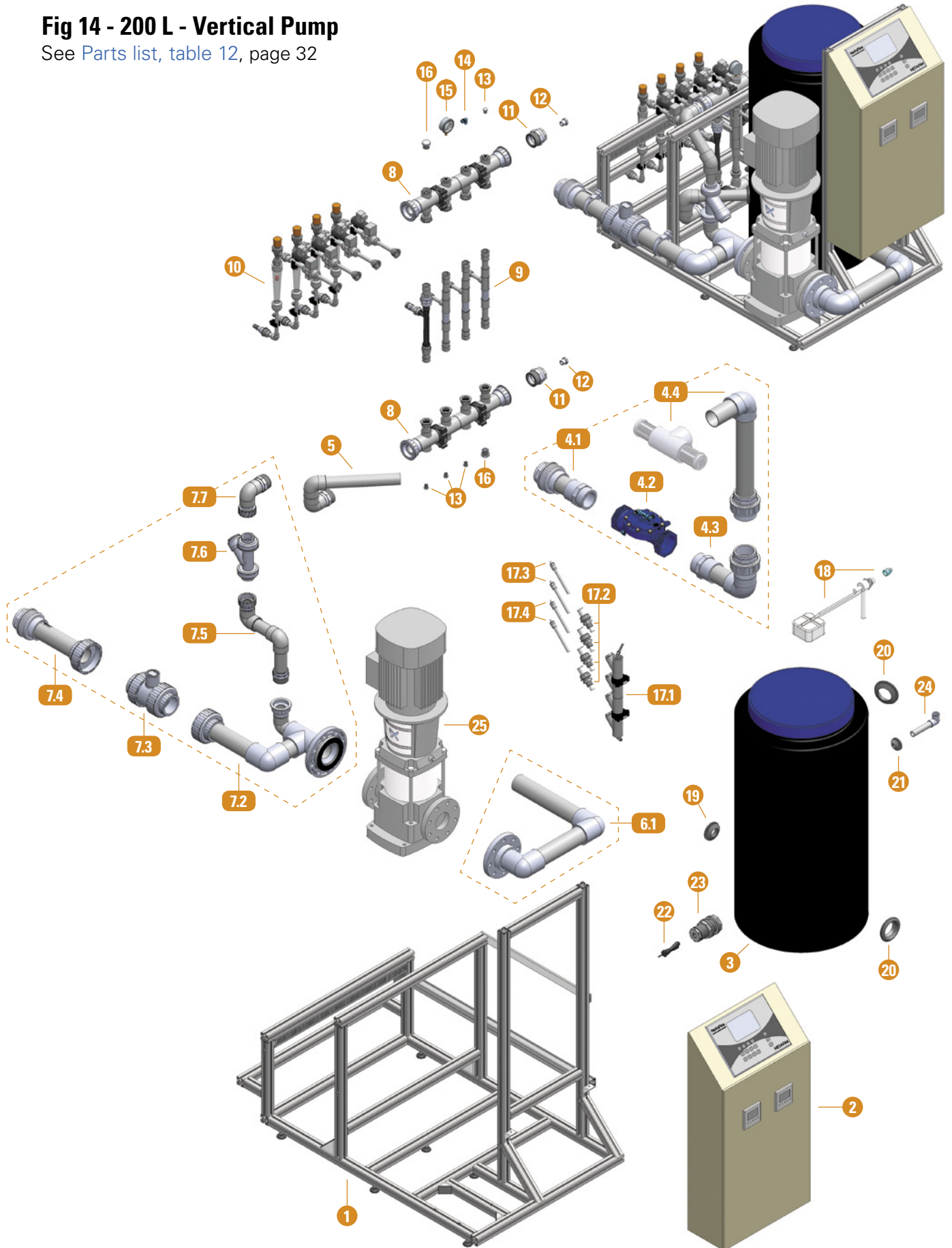

APPENDIX 1 - NetaFlex™ 3G PARTS LIST

Table 12 - Main parts (described in figures 13-14, pages 30-31)

Part	Description	Cat. No.
1	Frame for NetaFlex™ 3G	Not supplied as spare part
2	Control unit	Per NetaFlex™ 3G Serial Number*
3	Water Tank 100L-black 55cm diam. 57cm high	77600-001410
	Water Tank 200L-black 55cm diam. 114cm high	77600-001985
4.1	System Inlet	Per NetaFlex™ 3G Serial Number*
4.2	Float Valve	
4.3	Float valve to tank adaptor	
4.4	Difuser Kit	
5	Lower manifold to tank adaptor	33240-006400
6.1	Inlet to pump	Per NetaFlex™ 3G Serial Number*
6.2	Tank Outlet	
7.1	Outlet from pump adaptor	
7.2	Outlet from pump manifold	
7.3	Check valve	
7.4	Outlet from check valve	
7.5	Outlet from pump manifold to filter adaptor	
7.6	Filter	
7.7	Filter to upper manifold adaptor	
8	Upper / lower manifold	33240-002100
9	Venturi	See page 34
10	Dosing channel	See page 33
11	Reducer 50mm - 1/2"	33240-002251
12	PVC threaded plug 1/2" - male	77300-016010
13	Plug 1/4"	77300-016000
14	Control tube elbow connector 8*1/4 FT58	71000-031970
15	Pressure gauge - 250 GLZ 8 bar (116 PSI) 1/4" BSP	77540-003350
16	PVC threaded plug 3/4" - male	77400-027100
17.1	EC/pH manifold	Per NetaFlex™ 3G Serial Number*
17.2	Union adaptor set for EC/pH sensor	33120-008500
17.3	EC sensor Jumo temperat comp. PT100 12mm	45000-006705
17.4	pH sensor Jumo 12mm plastic bared wires	45000-006701
18	Water level float 1/2"	75080-002900
19	Penetration seal for Lower manifold to tank adaptor	77600-014000
20	Penetration seal for Tank Inlet/Outlet	Per NetaFlex™ 3G Serial Number*
21	Penetration seal for Overflow assembly	77600-006510
22	Low level switch	77100-007930
23	Low level switch casing	33240-006220
24	Overflow assembly	33240-006450
25	System pump	See page 35

* For spare part ordering call your local Netafim™ representative having at hand the Serial Number of your NetaFlex™ 3G.

Only with this number we can supply the correct part for your specific NetaFlex™ 3G.

The Serial Number is inscribed on the side of the switchbox (3530-_____).

APPENDIX 1 - NetaFlex™ 3G PARTS LIST

Dosing channel

Fig 15

See Parts list, table 13, page 34

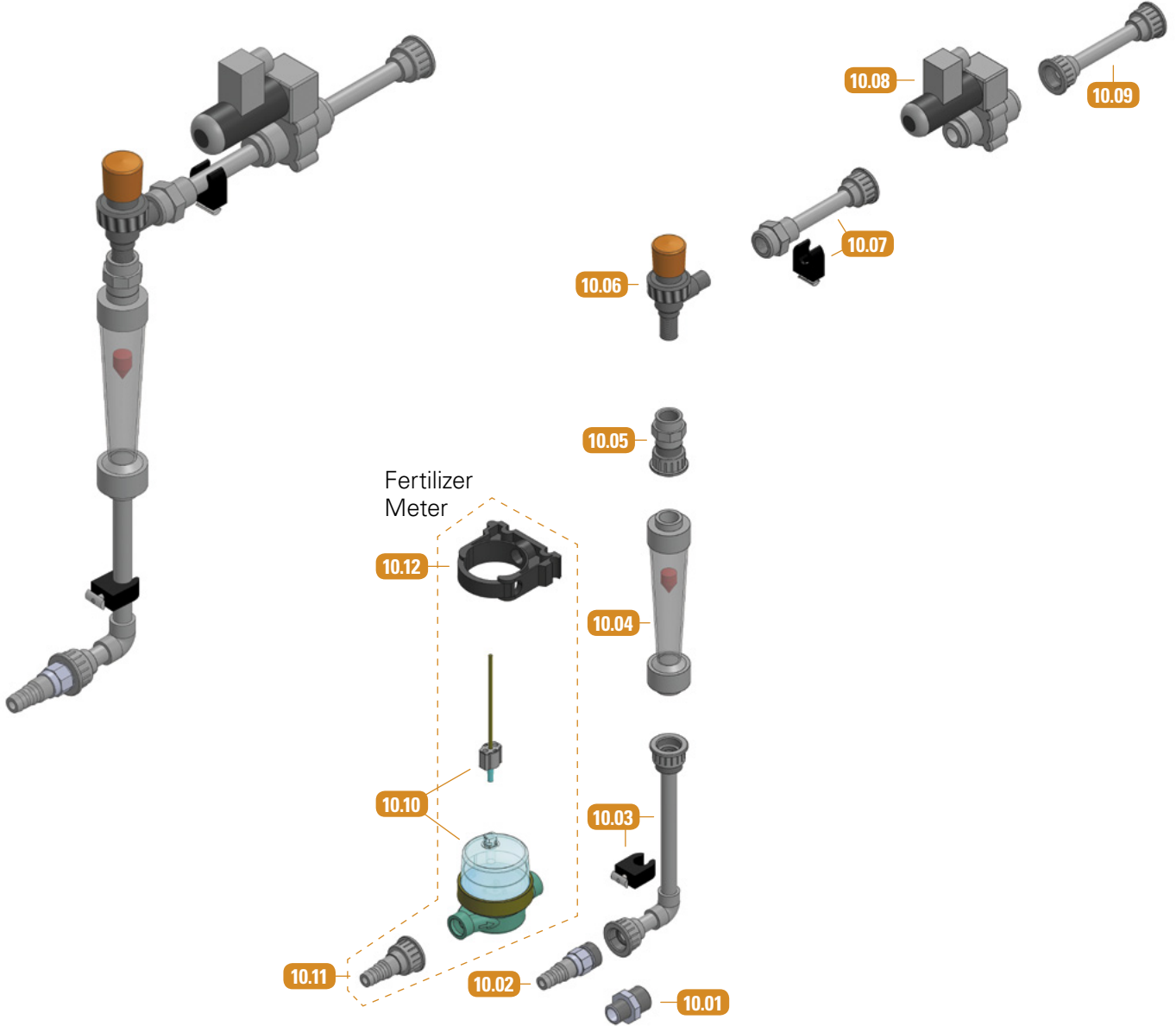

APPENDIX 1 - NetaFlex™ 3G PARTS LIST

Table 13 - Dosing channel parts (described in figure 15, page 33)

Part	Description	Notes	Cat. No.
10.01	Nipple 3/4" 1/2"		77300-010470
10.02	FSP - Hose nozzle end connector for dosing channel		33240-004200
10.03	FSP - Dosing channel connection between hose nozzle and Rotameter valve DFM170	Suitable for dosing channels 50l/h (13 GPH), 150l/h (40 GPH) and 400l/h (106 GPH)	33240-004250
	FSP - Dosing channel connection between hose nozzle and Rotameter valve DFM185	Suitable for dosing channels 600l/h (158 GPH)	33240-004300
10.04	Rotameter DFM170 5-50 l/h (1.3-13 GPH)		77540-007560
	Rotameter DFM170 15-150 l/h (4-40 GPH)		77540-007575
	Rotameter DFM170 40-400 l/h (10.6-106 GPH)		77540-007570
	Rotameter DFM185 60-600 l/h (15.8-158 GPH)		77540-007577
10.05	FSP - Dosing channel connection between Rotameter and needle valve DFM170	Suitable for dosing channels 50l/h (13 GPH), 150l/h (40 GPH) and 400l/h (106 GPH)	33240-004350
	FSP - Dosing channel connection between Rotameter and needle valve DFM185	Suitable for dosing channels 600l/h (158 GPH)	33240-004400
10.06	Needle valve RPRV 1/2" FPM, 1000l/h (265 GPH)		77500-004850
10.07	FSP - Dosing channel connection between needle valve and dosing valve S12	Suitable for dosing channels 600 l/h (158 GPH) with dosing valve Fip S12	33240-004440
10.08	Dosing valve S12	Suitable for dosing channels 600 l/h (158 GPH)	77540-008480
10.09	FSP - Dosing channel connection between dosing valve S12 and Venturi		33240-004580
10.10	Fertilizer Meter SF 1/2" EV 0.1L	Pulse/Qty. ratio 0.1L/Pulse	70240-005700
	Fertilizer Meter SF 3/4" EV 0.1GAL	Pulse/Qty. ratio 0.1GAL/Pulse	70261-011000
10.11	FSP - Hose nozzle end connector for fertilizer meter		33240-005250
10.12	FSP - Mounting kit for Fertilizer Meter		33240-005500

Venturis

Table 14

Part	Description	Cat. No.
9.01	Venturi - PVDF-M50	33240-003200
9.02	Venturi - PVDF-M50 Dual	33220-003210
9.03	Venturi - PP-N150	33240-002300
9.04	Venturi - PVC-N600	33240-002370
9.05	Venturi - PVC-N600 Dual	33240-002375

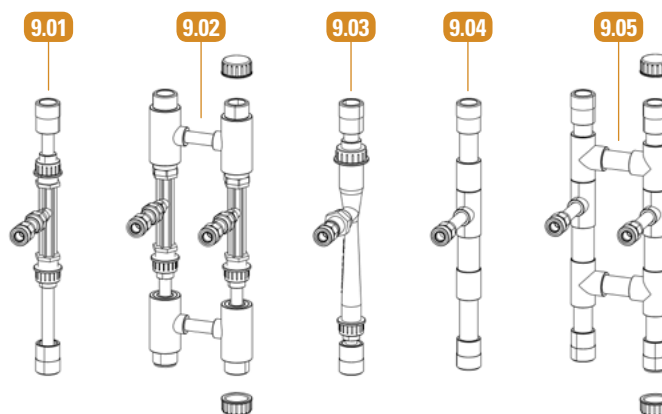

Fig 16

APPENDIX 2 - SYSTEM PUMP LIST

System pump list

Table 15 - For 50 Hz installations

Pump	Electrical data
CM 10-3	Rated power: P2: 2.2 kW
	Rated voltage: 3 x 230Δ/400Y V
	Nominal current: 8.15/4.7 A
	Consumption*: 2.35 kW
Required circuit breaker: 6.3-10/4-6.3 A	
CM 10-4	Rated power: P2: 3.2 kW
	Rated voltage: 3 x 230Δ/400Y V
	Nominal current: 11.8/6.75 A
	Consumption*: 3.35 kW
Required circuit breaker: 10-6/6.3-10 A	
CM 15-4	Rated power: P2: 4.0 kW
	Rated voltage: 3 x 230Δ/400Y V
	Nominal current: 14.0/8.2 A
	Consumption*: 4.15 kW
Required circuit breaker: 13-18/6.3-10 A	
CM 25-2	Rated power: P2: 4 kW
	Rated voltage: 3 x 230Δ/400Y V
	Nominal current: 14.0/8.2 A
	Consumption*: 4.15 kW
Required circuit breaker: 13-18/6.3-10 A	
CM 25-3	Rated power: P2: 5.8 kW
	Rated voltage: 3 x 230Δ/400Y V
	Nominal current: 20.4/11.8 A
	Consumption*: 5.95 kW
Required circuit breaker: 20-25/10-16 A	
CR 32-3-2	Rated power: P2: 5.5 kW
	Rated voltage: 3 x 400Δ V
	Nominal current: 11.0 A
	Consumption*: 5.65 kW
Required circuit breaker: 10-16 A	
CR 32-3	Rated power: P2: 5.5 kW
	Rated voltage: 3 x 400Δ V
	Nominal current: 11.0 A
	Consumption*: 5.65 kW
Required circuit breaker: 10-16 A	
CR 45-2	Rated power: P2: 11 kW
	Rated voltage: 3 x 400Δ V
	Nominal current: 20.8 A
	Consumption*: 11.15 kW
Required circuit breaker: 20-25 A	
CR 45-3-2	Rated power: P2: 11 kW
	Rated voltage: 3 x 400Δ V
	Nominal current: 14.4 A
	Consumption*: 11.15 kW
Required circuit breaker: 20-25 A	
CR 64-2-1	Rated power: P2: 11 kW
	Rated voltage: 3 x 400Δ V
	Nominal current: 20.8 A
	Consumption*: 11.15 kW
Required circuit breaker: 20-25 A	
CR 64-2	Rated power: P2: 11 kW
	Rated voltage: 3 x 400Δ V
	Nominal current: 20.8 A
	Consumption*: 11.15 kW
Required circuit breaker: 20-25 A	

Table 16 - For 60 Hz installations

Pump	Electrical data
CM 10-2	Rated power: P2: 2.5 kW
	Rated voltage: 3 x 220Δ/440Y V
	Nominal current: 8.95/4.3 A
	Consumption*: 2.65 kW
Required circuit breaker: 6.3-10/4-6.3 A	
CM 10-3	Rated power: P2: 4 kW
	Rated voltage: 3 x 220Δ/440Y V
	Nominal current: 14.8/7.2 A
	Consumption*: 4.15 kW
Required circuit breaker: 13-18/6.3-10 A	
CM 15-2	Rated power: P2: 4 kW
	Rated voltage: 3 x 220Δ/440Y V
	Nominal current: 14.8/7.2 A
	Consumption*: 4.15 kW
Required circuit breaker: 13-18/6.3-10 A	
CM 25-2	Rated power: P2: 6 kW
	Rated voltage: 3 x 220Δ/440Y V
	Nominal current: 21.0/10.5 A
	Consumption*: 6.15 kW
Required circuit breaker: 20-25/10-16 A	
CR 32-2-2	Rated power: P2: 5.5 kW
	Rated voltage: 3 x 440Δ V
	Nominal current: 10.6 A
	Consumption*: 5.65 kW
Required circuit breaker: 10-16 A	
CR 32-2	Rated power: P2: 7.5 kW
	Rated voltage: 3 x 440Δ V
	Nominal current: 14.2 A
	Consumption*: 7.65 kW
Required circuit breaker: 10-16 A	
CR 45-2-2	Rated power: P2: 11 kW
	Rated voltage: 3 x 440Δ V
	Nominal current: 20.8 A
	Consumption*: 11.15 kW
Required circuit breaker: 20-25 A	
CR 45-1	Rated power: P2: 7.5 kW
	Rated voltage: 3 x 440Δ V
	Nominal current: 14.2 A
	Consumption*: 7.65 kW
Required circuit breaker: 13-18 A	
CR 64-1	Rated power: P2: 11 kW
	Rated voltage: 3 x 440Δ V
	Nominal current: 20.8 A
	Consumption*: 11.15 kW
Required circuit breaker: 20-25 A	
CR 64-2-2	Rated power: P2: 15 kW
	Rated voltage: 3 x 440Δ V
	Nominal current: 28.0 A
	Consumption*: 15.5 kW
Required circuit breaker: 28-40 A	

*Total power consumption of the NetaFlex™ 3G with the mentioned system pump, controller, dosing valves, etc.

GROW MORE WITH LESS

WWW.NETAFIM.COM